

**18C  
4017N**

## VW T6, Modell 2019

EU-Spoilerschutzrohr 51 mm gekröpft  
EU-Spoiler protective tube 51 mm cranked  
Tube de protection du spoiler vinkläd CE 51 mm



\*Compatible with Automatic Cruise Control /Forward Collision Mitigation  
Kompatibel mit Abstandsregeltempomat /Auffahrvermeidungs-oder warnsystem  
compatible avec radar de régulation de distance/ freinage autonome d'urgence

# ASSEMBLY INSTRUCTION

Montageanleitung • Instructions de montage

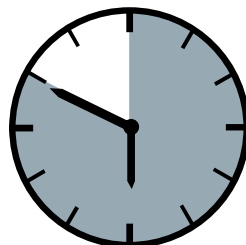

**50 Minuten**

article no.:

18C4017N (S) inox

18C5017N black steel

Revision 2: 06.02.2020



[www.antec-online.de](http://www.antec-online.de)

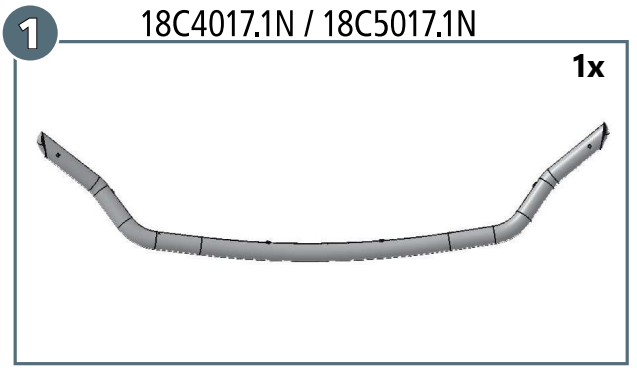
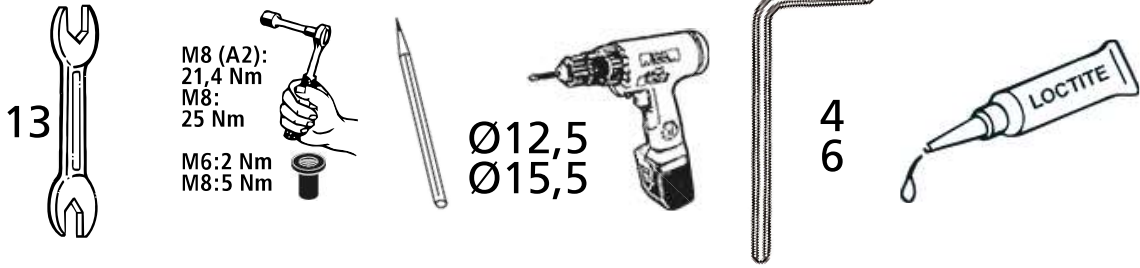

mounting kit: 18C9017N

|  |                   |           |
|--|-------------------|-----------|
|  | M8x25; DIN 933 A2 | <b>4x</b> |
|  | M8x25; DIN 933 Zn | <b>2x</b> |
|  | M8x16; DIN 933 Zn | <b>4x</b> |
|  | M6x30; DIN 912 A2 | <b>2x</b> |
|  | M6x25; DIN 7991   | <b>4x</b> |
|  | Ø 6,4; DIN 125 A2 | <b>2x</b> |
|  | GETO-WELL M6      | <b>6x</b> |

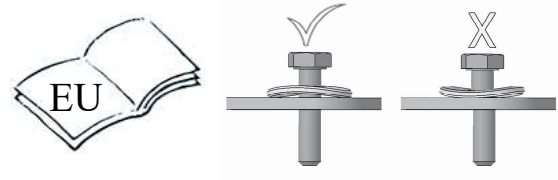
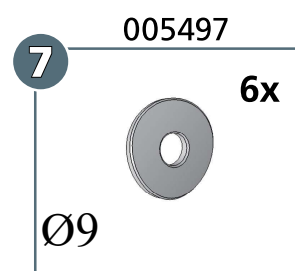
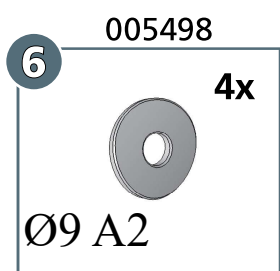
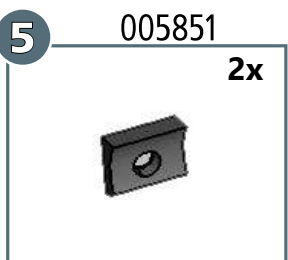
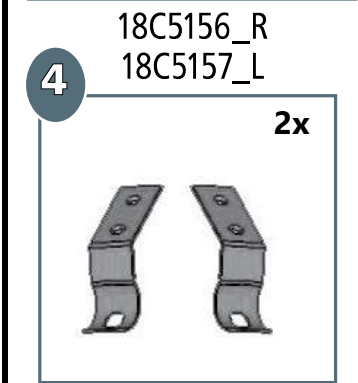
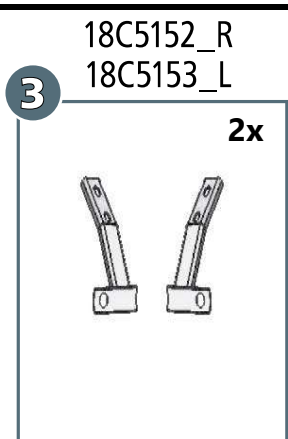
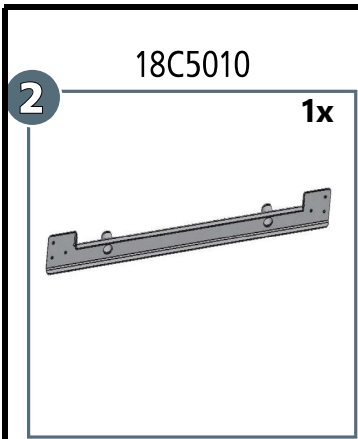

article no.:  
18C4017N (S) inox  
18C5017N black steel

Revision 2: 06.02.2020



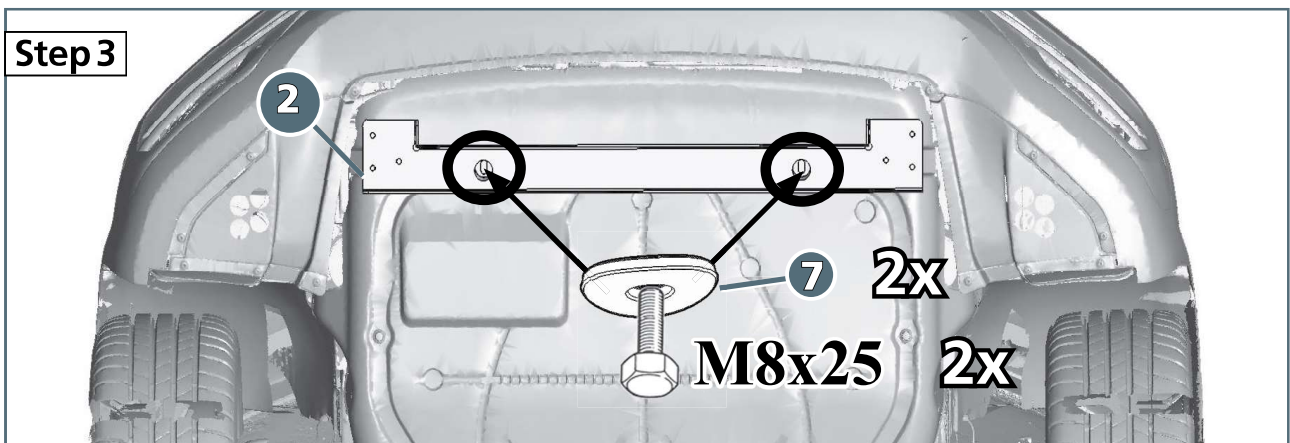
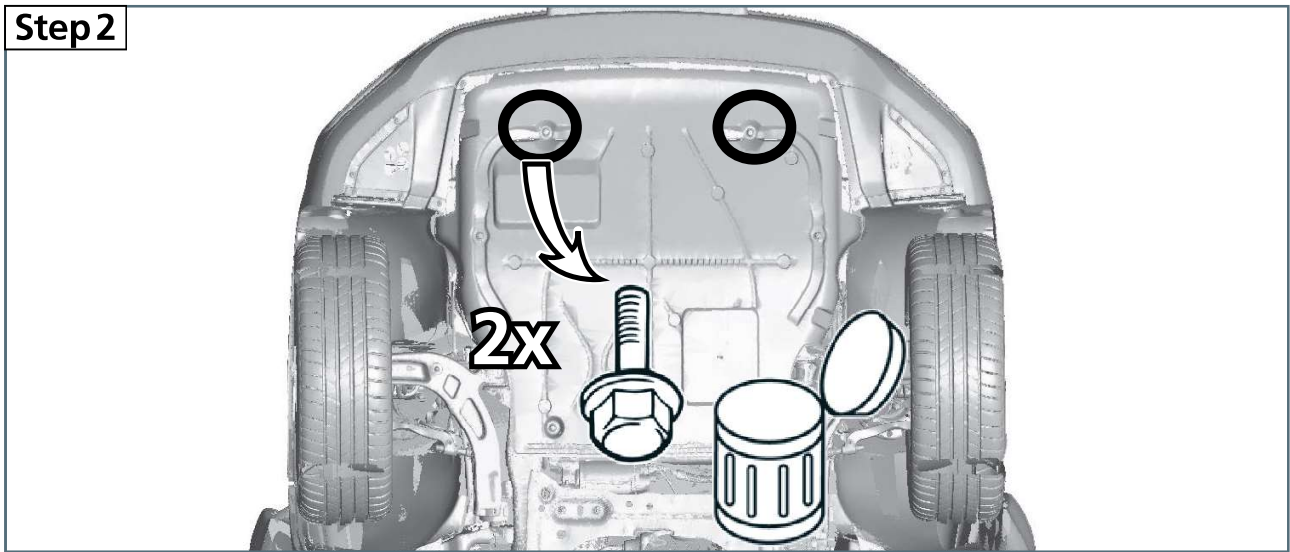
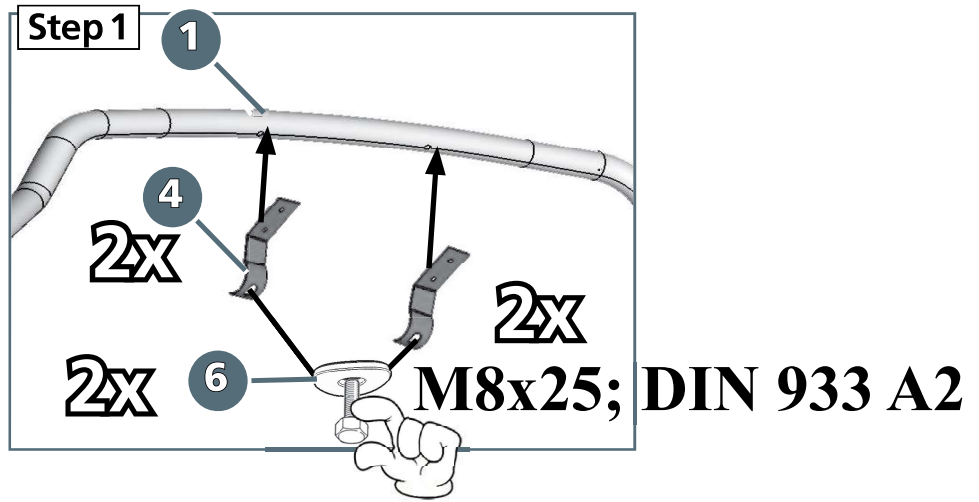

Revision 2: 06.02.2020

Step 5

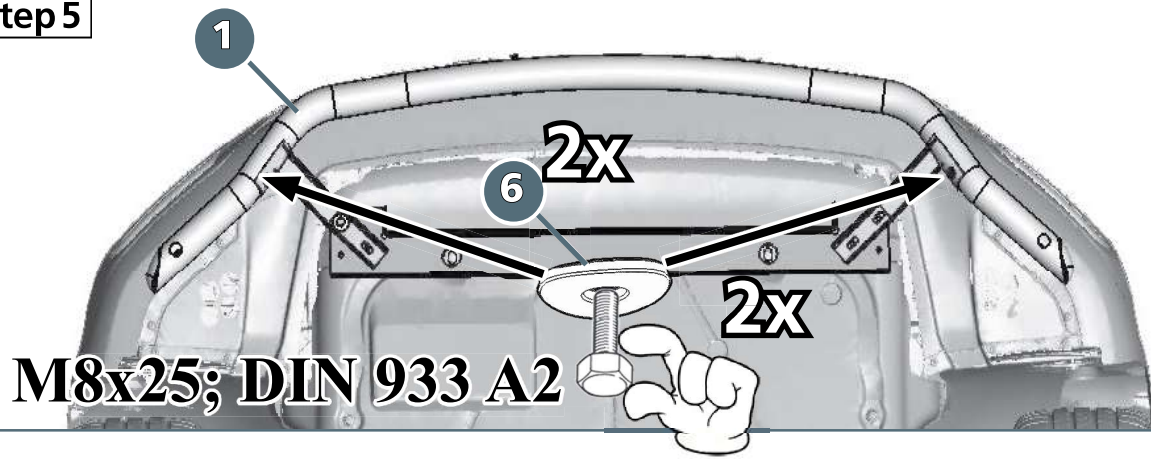

Step 6

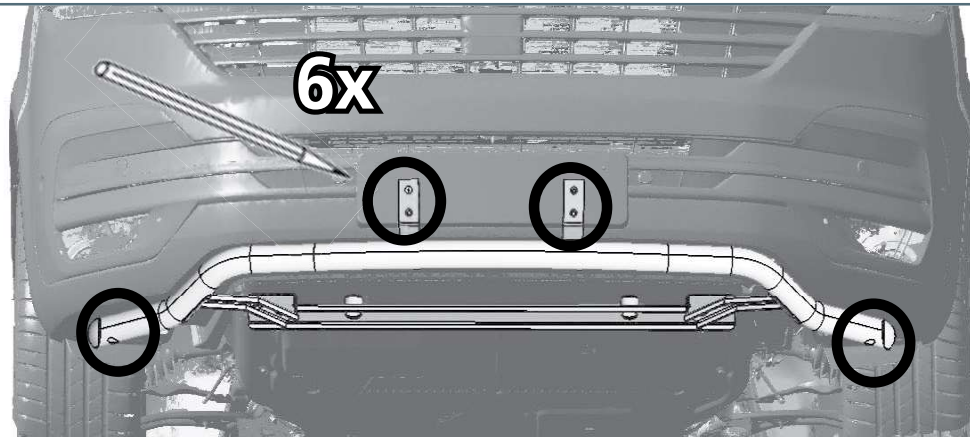

Step 7

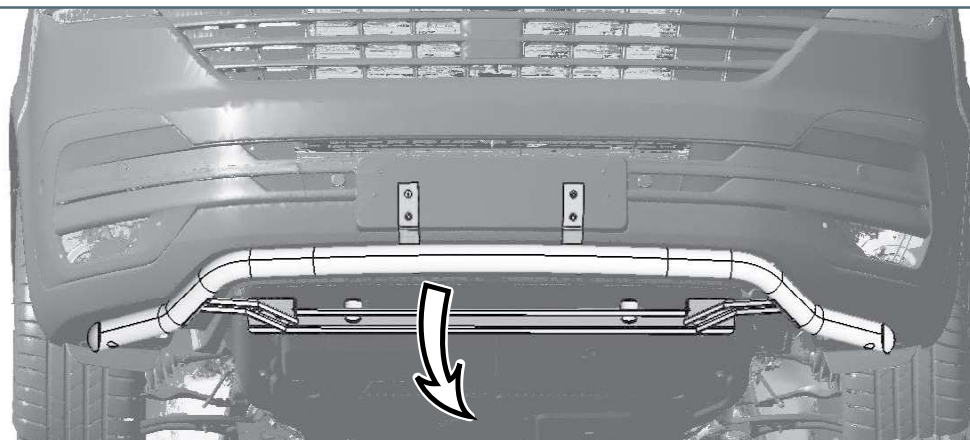

Step 8

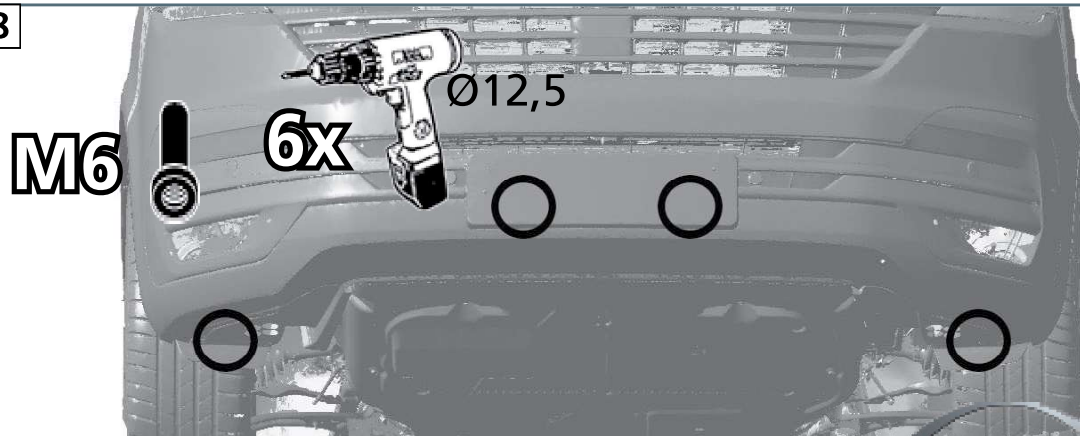



Step 9

5  
2x

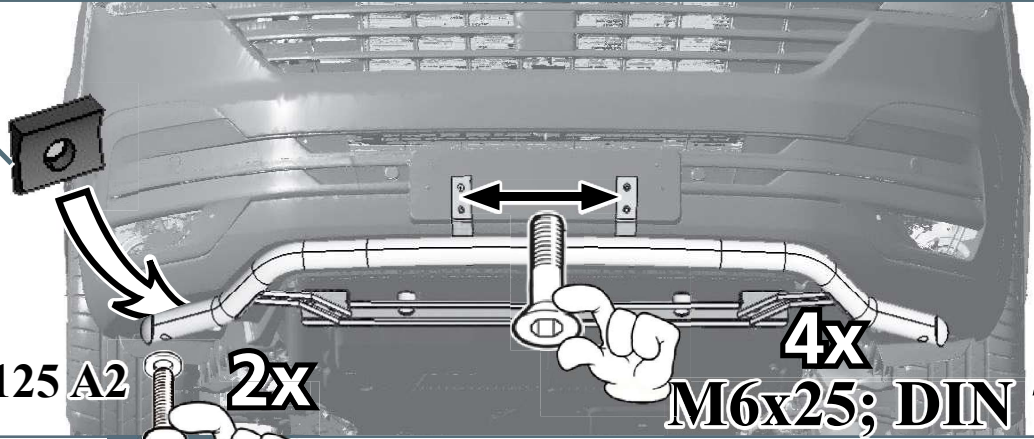

Ø6,4; DIN 125 A2  
M6x30-A2

2x

4x  
M6x25; DIN 7991

Step 10

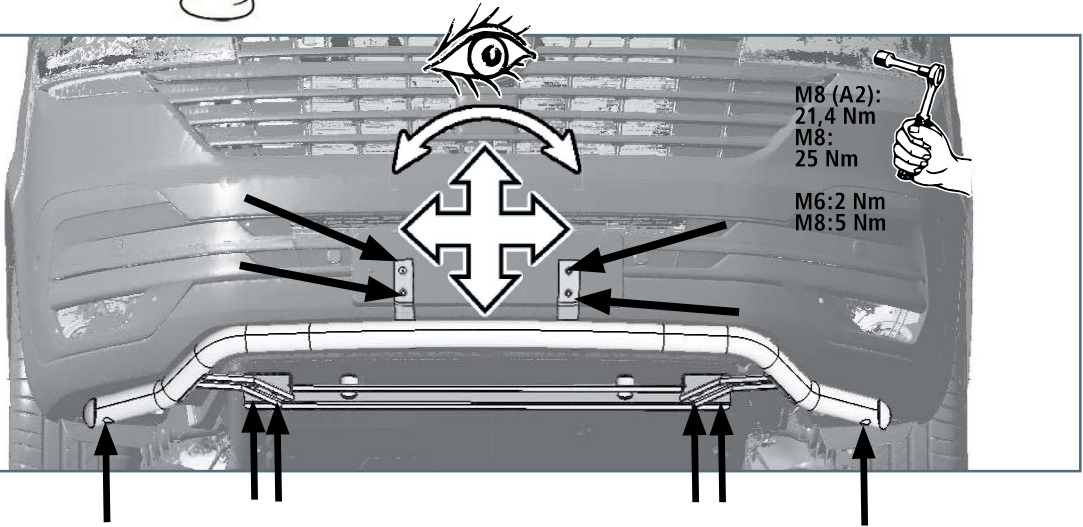

M8 (A2):  
21,4 Nm  
M8:  
25 Nm  
  
M6: 2 Nm  
M8: 5 Nm

Step 11

